

# MANOMETROS

SERIE URM 1/8 - 1/4 NPT

Art



## Características

- Lectura de presiones en sistemas neumáticos para un óptimo funcionamiento

## Manómetro Cuadrado

Referencia	Rango PSI (BAR)	Montaje/tipo
URM14	0 - 140 (0 - 10)	Integrado al regulador / Cuadrado
URMA01		Adaptador cuadrado para instalar manómetro redondo de 1/8"
URMA02		Adaptador cuadrado para instalar manómetro redondo de 1/4"

## Datos Técnicos

Fluido:  
Aire comprimido

Temperatura de Trabajo:  
-20°C a 60°C ~ -4°F a 140°F

## Manómetros Standard

Referencia	NPT	Rango PSI (BAR)	Ø Caratula	Tipo
URM0122	1/8"	0 - 60 (0 - 4)	40	Redondo
URM0124	1/8"	0 - 140 (0 - 10)	40	Redondo
URM0134	1/8"	0 - 140 (0 - 10)	40	Flanche P/Tablero
URM0164	1/8"	0 - 140 (0 - 10)	40	Clip P/Tablero
URM0222	1/4"	0 - 60 (0 - 4)	50	Redondo
URM0224	1/4"	0 - 140 (0 - 10)	50	Redondo
URM0234	1/4"	0 - 140 (0 - 10)	50	Flanche P/Tablero
URM0244	1/4"	0 - 140 (0 - 10)	60	Flanche P/Tablero
URM0274	1/4"	0 - 140 (0 - 10)	50	Clip P/Tablero
URM0284	1/4"	0 - 140 (0 - 10)	60	Clip P/Tablero

## Materiales

Cuerpo : Plástico  
Tapa : Plástico  
Partes en movimiento : Cobre / latón

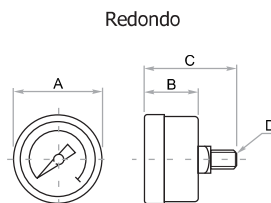
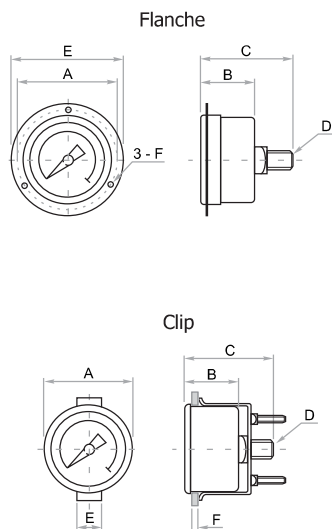

Ref.	A	B	C	D	E	F
URM0122	42	24,5	38,5	1/8"	-	-
URM0124	52	24,5	38,5	1/8"	-	-
URM0134	52,5	24,5	40,5	1/8"	60	3,4
URM0164	42	28	43,5	1/8"	21	5
URM0222	52	26,5	44,5	1/4"	-	-
URM0224	52	26,5	44,5	1/4"	-	-
URM0234	52	27,5	47,5	1/4"	71	4,4
URM0244	62	30	50	1/4"	82	4,4
URM0274	52	30,5	50	1/4"	24	7
URM0284	62	30,5	50	1/4"	25	7